

Ready-Set-Sew

Getting Started Guide



Congratulations on the purchase of your new sewing machine. We've compiled a few tips that will help you get the most out of your new purchase and increase your enjoyment of sewing.

Note: Your machine may vary from these illustrations. Always refer to your instruction manual for exact details on your machine.

Bobbin Winding

In order to ensure correct bobbin winding, follow the below diagram for correct threading. Use both hands to thread machine around the guide for correct tension.

Pro tip: Because different brands of thread unwind in various manners, sometimes it is helpful to lightly hold/guide the thread as it comes off the spool. This will help create smooth and tightly wound bobbins - which is important for a good stitch.

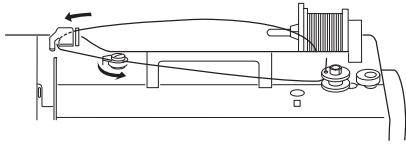
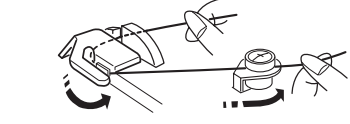
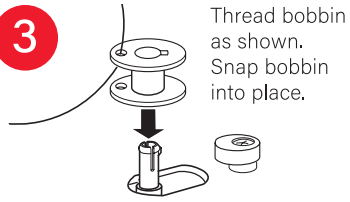
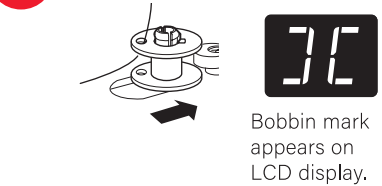
- 1** Guide thread from back to front.

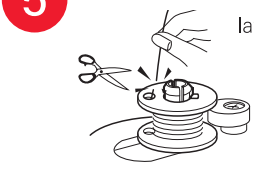
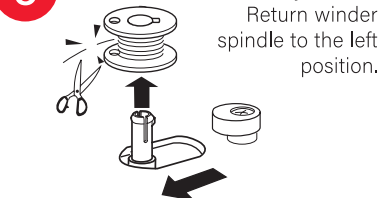
- 2** Guide thread into bobbin winder tension disk.

- 3** Thread bobbin as shown. Snap bobbin into place.

- 4** Push bobbin winder spindle to the right. Start the machine.

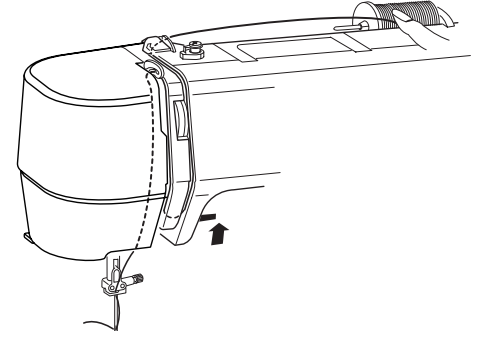
Bobbin mark appears on LCD display.
- 5** Stop the machine to snip the tail once a few layers are wound. Restart the machine.

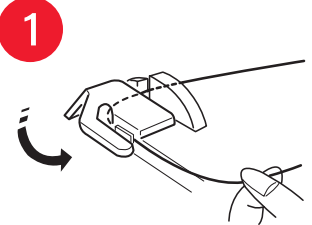
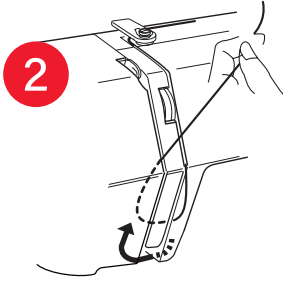
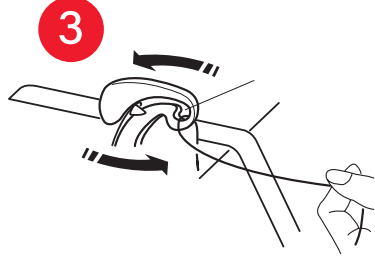
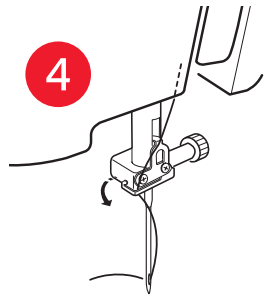
- 6** Machine will stop winding when fully wound. Return winder spindle to the left position.

Threading The Machine

Before you begin to thread, make sure the presser foot is in the up position and the needle is at the highest position. Lift the foot by using the presser foot lifter. Press the needle up/down button  to raise the thread take up lever to its highest position. This will help ensure that the threading guides are in the proper position to receive the thread.



- 1** Spool off enough thread. Hold upper thread at the reel and thread with other hand. Slip thread under top thread guide.

- 2** Guide thread down right channel and around the bottom of the thread guide plate. Pull firmly to ensure thread slots into tension disks.

- 3** Firmly, draw thread up left channel and into the thread take-up lever.

- 4** Then, down to lower thread guide. (see next page on needle threader)

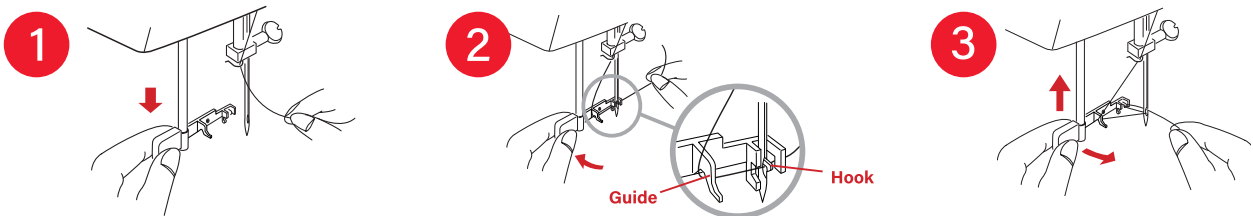
Getting Started Guide

Using the Needle Threader

Raise the needle to its highest position by pressing the needle up/down button. Pull down the needle threader knob as far as it will go. Turn the knob in the direction of the arrow in the second illustration, then insert the Hook into the needle eye. Lead the thread around the Guide and under the Hook. Turn the knob in the direction of the arrow in the third illustration, drawing the thread loop through the needle. Pull the thread through the needle eye.



Bobbin Threading

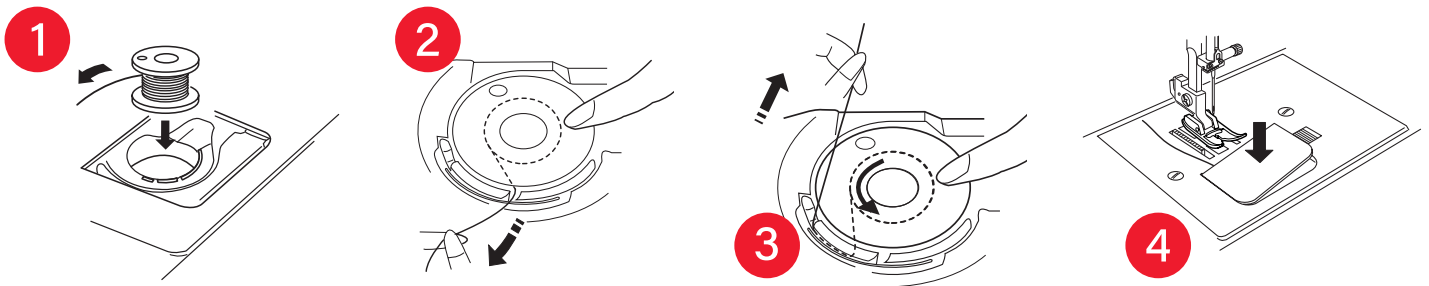

Before inserting the bobbin into the bobbin case, hold the bobbin in your hand and make sure that the thread is coming off the bobbin in a counterclockwise direction (it should look like a "P"). This will allow the bobbin thread to move correctly and to stay lodged in the bobbin tension guide.

Picking up the Bobbin Thread

Before you begin to sew, the bobbin thread needs to be pulled up onto the sewing bed. Gently hold the needle thread and press the needle up/down button  twice, you will see the bobbin thread looped around the needle thread. Using your fingers, grab the bobbin thread and pull up a 15cm/6" length.

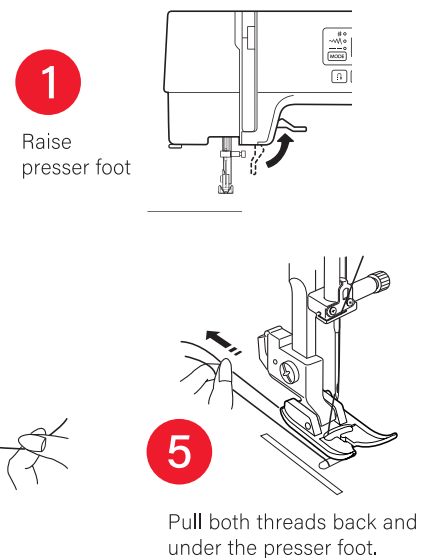

1
Raise
presser foot

2
Hold the needle
thread lightly with
your left hand.

3
Turn the power on.
Press the needle up/
down button twice.

4
Pull up
bobbin thread.

5
Pull both threads back and
under the presser foot.

Sewing Over Thick Fabrics

Even though sewing machines can handle all types of fabrics, it's important to keep in mind that when sewing on thick fabrics like denim, that seams can become very thick. It is important to keep the presser foot level when sewing over these seams or uneven surfaces.

Pro tip: A quick fix is to fold a scrap of fabric 2 – 3 times and put it behind the needle and underneath the presser foot when you approach the seam or hump in your fabric. This will help to level your foot and keep your fabric feeding correctly.

The Thread Loops on the Underside or Topside of the Fabric

Pro tip: Problems with your stitching are the opposite of what you might think. If the thread is looping on the underside, re-check the upper threading on your machine. The thread may not be correctly seated in the tension disks or has come out of the Take Up lever.

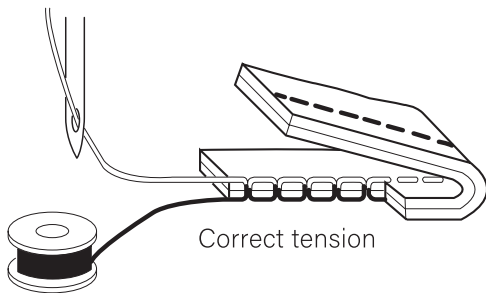

Conversely, if the thread is looping on top, make sure the bobbin thread is coming off the bobbin counter-clockwise and that the thread is securely threaded in the bobbin tension guide.

Refer to your instruction manual for more information.

Machine or Needle is Jammed

Using scissors, carefully cut away thread above and below fabric. Gently pull the fabric away from the presser foot area, while making slight turns on the handwheel to raise the needle.

Inspect the needle to make sure it isn't bent. If so, replace it. Before re-threading the needle, turn the handwheel toward you making sure that there isn't any more thread or fabric in the feed dogs or in the bobbin area.

Pro tip: When you are done stitching, make sure that the needle is in the highest position before you remove your fabric from the machine. This will ensure that the upper thread has made a full rotation around the bobbin case, preventing thread jams in the bobbin area.

Machine Won't Turn On

Check to make sure that the cord is plugged into the wall.

Check to make sure that the power cord is plugged into the sewing machine.

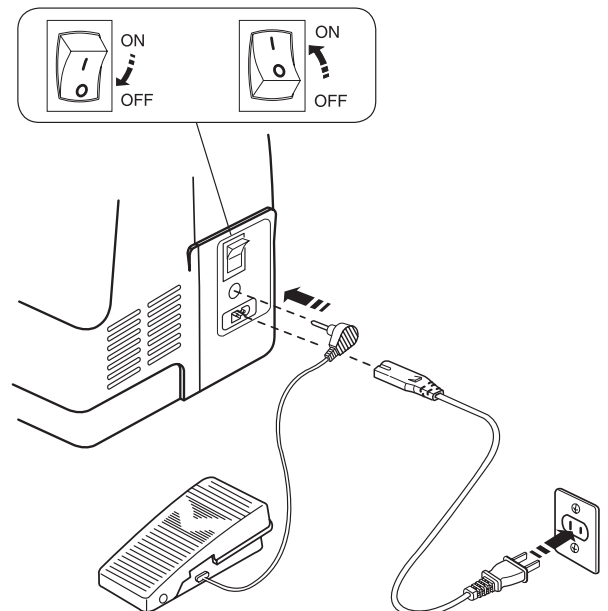

Troubleshooting Tips

Top Tips

Always turn the handwheel towards you

Anti-clockwise. Turning away from you can cause threads to tangle and break when starting to sew.

No Power

Check main power supply is turned on, power cord and foot control are connected.

Overlocker Not Feeding Fabric

Check that the Feed Dogs are raised and clean. These are the teeth under the presser foot that feed the fabric when stitching. When the drop feed lever is moved from the lowered position to the raised position the feed teeth do not come up at the needle plate until you turn the handwheel wheel towards you one full revolution.

Check that the stitch length is set for correct weight of fabric.

Tip: increasing the stitch length increases the feed dog function to pull through more fabric.

Skipped / Bad Stitching

Rethread the machine with the presser foot raised and the take up lever in the highest position. Follow the threading guides and check that the thread is in the take up lever.

Check that the needle is inserted correctly, flat side to the back.

Check that the needle is not bent or blunt and is the correct type of needle.

Check that the tension setting is correct (average setting for a straight stitch is approx. 4).

Check that the tension disk area is clean.

Check that the bobbin is placed in the bobbin holder correctly. The bobbin should turn anti-clockwise when pulling the thread.

Elna sewing machines use Organ brand of needle, available from elna stockist. Using other needles may cause stitching issues.

Register your machine today



Happy Stitching!

